

# CHRONIC DISCIPLINE, BULLYING & CRITICAL THINKING

Building Empathy Using Real Legal Cases

**Colin Seale, thinkLaw Founder | CEO**

colin@thinkLaw.us

**www.thinkLaw.us**

Twitter: @thinkLawUS (#Liberty2Learn #GoldenPencil)

Twitter: @thinkLawUS

#Liberty2Learn #Golden Pencil

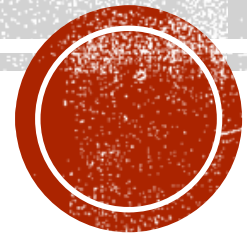



Twitter: @thinkLawUS  
#Liberty2Learn #Golden Pencil



# THINKSTARTER

Why did you choose this session:  
Chronic Discipline, Bullying &  
Critical Thinking?



Twitter: @thinkLawUS  
#Liberty2Learn #Golden Pencil



# ROADMAP

- Defining Empathy
- Connecting empathy to critical thinking
- Exploring how real-life legal cases and instruction grounded in the Socratic method can boost academic achievement and social-emotional growth
- Practical tools for moving forward



Twitter: @thinkLawUS  
#Liberty2Learn #Golden Pencil

# EMPATHY



## Harvard Study from **Making Caring Common**

- Surveyed 10,000 students in Middle and High Schools.
- In schools where students reported having more empathy, students also reported fewer experiences of bullying and were more likely to try to stop bullying
- Students who reported more empathy also reported fewer experiences of discrimination, threats to physical safety, teasing, and bullying at school.
- Higher reports of empathy were also associated with student reports of feeling more connected to their school and being more influenced by school values



# Empathy

*noun*

The ability to understand and share the feelings of another

## emotional empathy

The ability to respond with appropriate emotions

## intellectual empathy

The ability to hear thoughtfully. To imagine what it's like to share someone's experiences and convictions

[www.thinklawn.us](http://www.thinklawn.us)

THINK  
LAW



# We are in urgent need of critical thinkers.

California Released New Common Core–Aligned Test Results. Less Than Half of Students Made the Grade.

Common Core tests: About 1/3 of Louisiana pupils make 'mastery'

Education

A quarter of D.C. students 'on track' for college, PARCC test results show

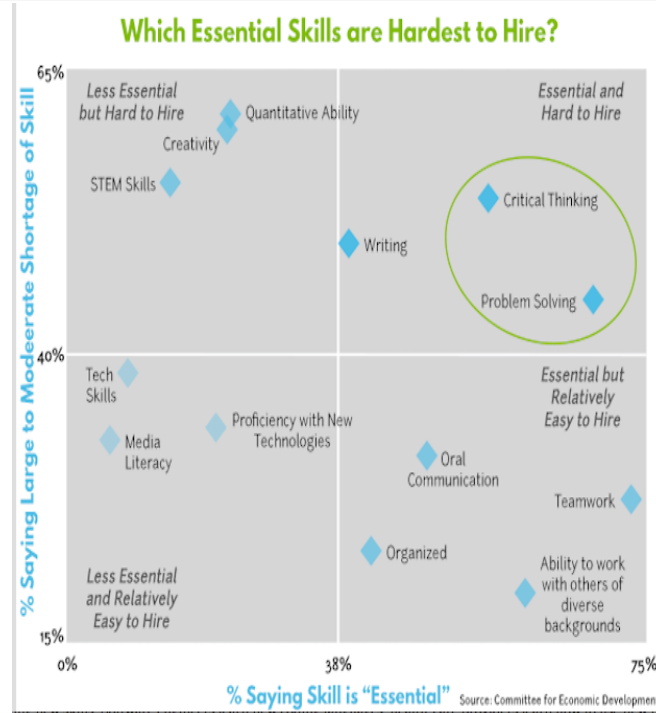

Employers More Interested in Critical Thinking and Problem Solving Than College Major



Most Illinois students fall short on new PARCC tests

Twitter: @thinkLawUS

#Liberty2Learn #Golden Pencil





It's not that I am so smart,  
it's just that I stay with  
problems longer.

-Albert Einstein



# THE PROBLEM:

Only 1 out of 10 educators teach critical thinking, and this person usually teaches at an **elite school** or only teaches critical thinking to **elite students**.

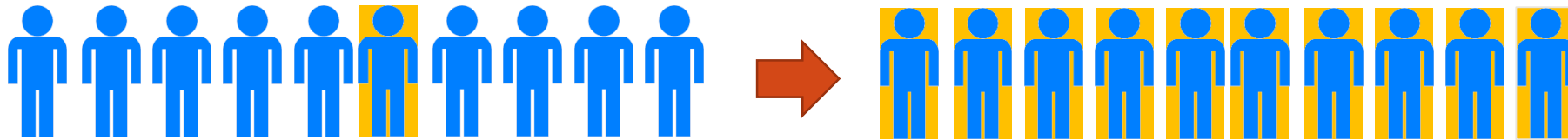

How do we teach critical thinking to **all students**?

# THE THINKLAW SOLUTION: THINKING “LIKE A LAWYER”

## Critical thinking skills + Critical thinking disposition

What if a lawyer’s critical thinking skills could be taught to **all students**?



What if you could appeal to students’ **inherent sense of justice and fairness** to motivate them to apply critical thinking as a **habit**?



Twitter: @thinkLawUS  
#Liberty2Learn #Golden Pencil

# THE CHAIR CASE

- Brian – 5 years old
- Aunt – sued Brian for battery
- Claim from Aunt – Brian pulled the chair away when she was about to sit down.
- Aunt fell on the floor and paid \$11,000 to the hospital to fix her hip that was hurt during the fall.



Twitter: @thinkLawUS

#Liberty2Learn #Golden Pencil

Copyright © 2017 by CS IP Holdings, LLC. All rights reserved.



# THINKANALYSIS

Element of Battery	Evidence supporting element (Plaintiff)	Evidence against element (Defendant)	Which evidence is stronger?
(1) Brian's act was intentional			
(2) Brian's act involved contact with another person			
(3) Brian's act was harmful or offensive			
(4) Brian's act caused damages			



Twitter: @thinkLawUS  
#Liberty2Learn #Golden Pencil



# THINKBIGPICTURE

1. Was there anything strange about this case?
2. Would you sue your 5 year old nephew if he did this to you?
3. Why do you think she is suing her own family member?



Twitter: @thinkLawUS

#Liberty2Learn #Golden Pencil

Copyright © 2017 by CS IP Holdings, LLC. All rights reserved.



# THINKWORLD

## PUBLIC POLICY: HOW WOULD THIS DECISION IMPACT THE WORLD WE LIVE IN?

1. Is there any other reason, not based on evidence, that Brian should or should not be liable for the lawsuit?
2. What would the world look like if it was okay to sue a 5 year old because he or she committed a prank?
3. What would the world look like if an adult could not sue for serious medical injuries just because the person who harmed him or her was only 5 years old? Why or why not?



Twitter: @thinkLawUS

#Liberty2Learn #Golden Pencil

Copyright © 2017 by CS IP Holdings, LLC. All rights reserved.



**TEXT THINK TO 66866 FOR A FREE SAMPLE LESSON**

## **Outcome**

**The Court decided Brian was liable for battery. The Court explained that even though Brian did not touch his aunt, he pulled out her chair just before she sat down. Therefore, her injury was “substantially certain” to occur. It did not matter that Brian may have not meant to hurt her. All that mattered is that he meant for her to hit the ground instead of her chair. Therefore, Brian was liable for battery.**



Twitter: @thinkLawUS  
#Liberty2Learn #Golden Pencil



# SKILLS: HOW WE WANT OUR STUDENTS TO THINK/WRITE/ARGUE?

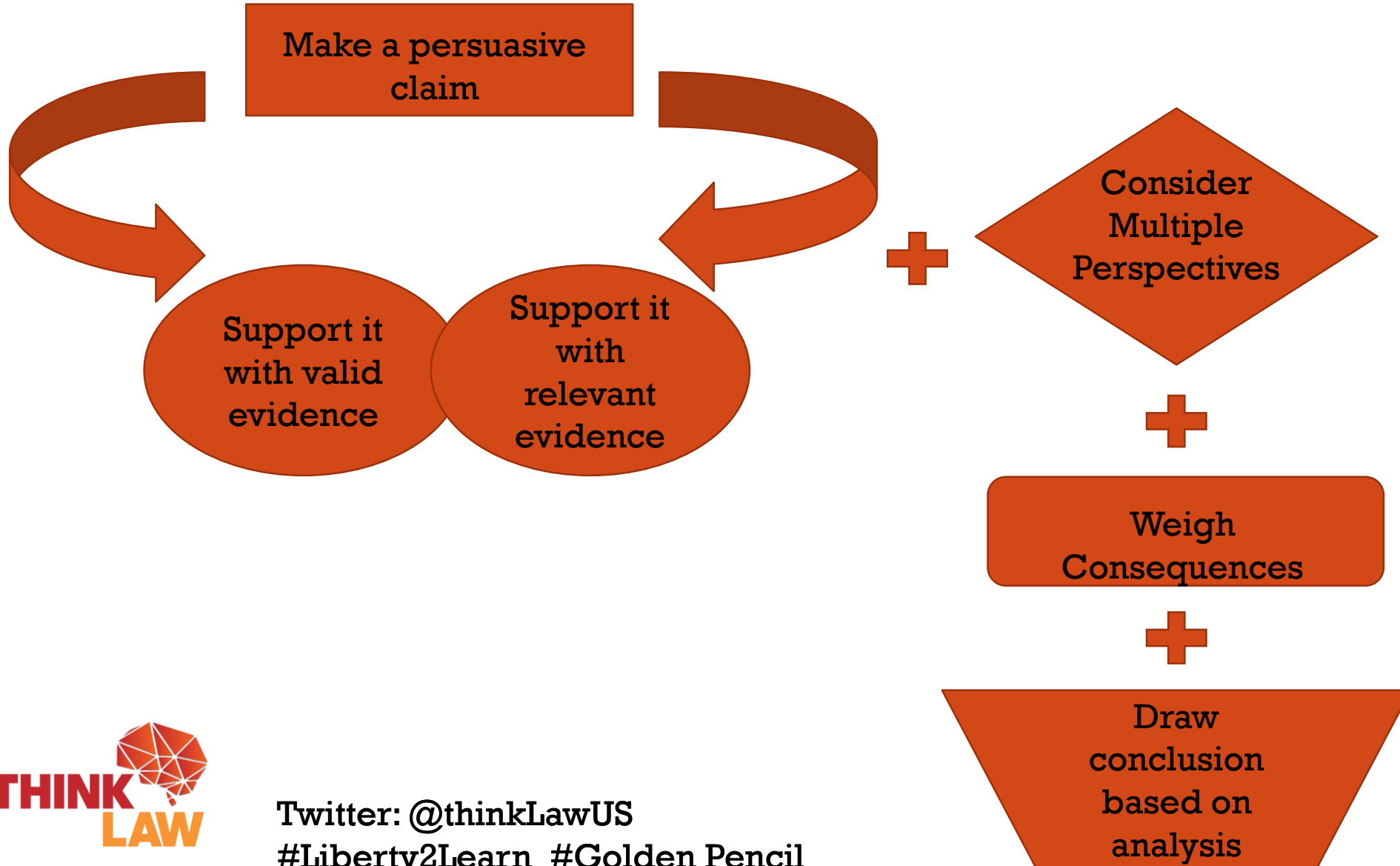



# MAKING CLAIMS AND SUPPORTING WITH EVIDENCE



## *Poem*

I loved my friend.  
He went away from me.  
There's nothing more to say.  
The poem ends.  
Soft as it began-  
I loved my friend



## Poem

I loved my friend.  
He went away from me,  
There's nothing more to say.  
The poem ends,  
Soft as it began -  
I loved my friend.

By Langston Hughes

Which line does the poet use the device of repetition? \_\_\_\_\_

What type of poem is this?  
\_\_\_\_\_

Twitter: @thinkLawUS  
#Liberty2Learn #Golden Pencil



# WHICH IS MORE RIGHT? WHY?

$$2x + 8 = 20$$

$$2x = 10$$

$$x = 5$$

$$2x + 8 = 20$$

$$2x = 12$$

$$x = 10$$



CELEBRATING  
BLACK  
HISTORY  
MONTH  
THROUGH  
CRITICAL  
THINKING



FAMOUS INVENTIONS

In 1923, Garrett saw a problem.



Many people were having car crashes. What did he invent to help solve this problem?

In 1891 John saw a problem.



A lot of food was going bad and rotting. What did he invent to help solve this problem?

In 1872, TJ saw a problem.



There were a lot of fires in big buildings and they were burning down. What did he invent to help solve this problem?

Name \_\_\_\_\_

Which invention do you think is the most important?

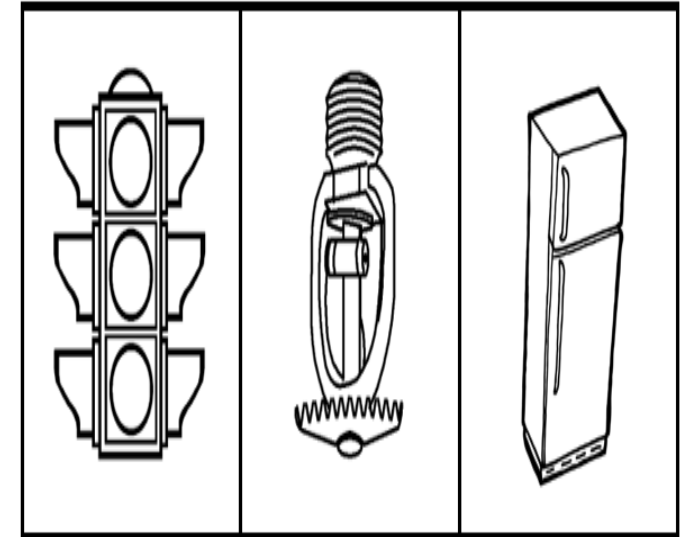

Why did you pick this invention?

**Text THINK to 66866 for a FREE sample lesson**

# CONFLICT RESOLUTION



# THINKNEGOTIATION

## The DIM Process

- 1) **Define** issues and interests
- 2) **Identify** BATNAs (will be explained later)
- 3) **Make** an opening offer



# THINKSTARTER

Karen and John (the dog owners) raise chickens and other animals at their home. Since 2002, the dog owners owned large dogs to protect their animals. Their dogs are Tibetan Mastiffs, and weigh over 150 pounds. These dogs are also very loud and start barking around 5:00am every morning and continue throughout the day. Dale and Debra (the neighbors), who lived next door to the dog owners before 2002, have trouble sleeping and cannot get any quiet moments in their home because of the loud barking. Animal control has already punished the dog owners for their noise violations, but the dog owners did not stop the noise. After a few years, the neighbors sued the dog owners because of this loud barking. The neighbors are asking the Court to force the dog owners to get rid of their dogs and pay the neighbors over \$200,000 for the damage caused by the loud dog barking over the last few years.

If you were the dog owners, what could you do to make this lawsuit go away? Come up with at least 3 ideas for settling this case.



Twitter: @thinkLawUS  
#Liberty2Learn #Golden Pencil



# CASE RESULT

A jury in Oregon awarded over \$200,000 in damages to the neighbors and forced the dog owners to “debark” their dogs – a surgery that involves modifying a dog vocal chords so the dog barks at a lower volume. If the dog owners did not want the dogs debarked, they had to get rid of the Tibetan Mastiffs.



Twitter: @thinkLawUS  
#Liberty2Learn #Golden Pencil





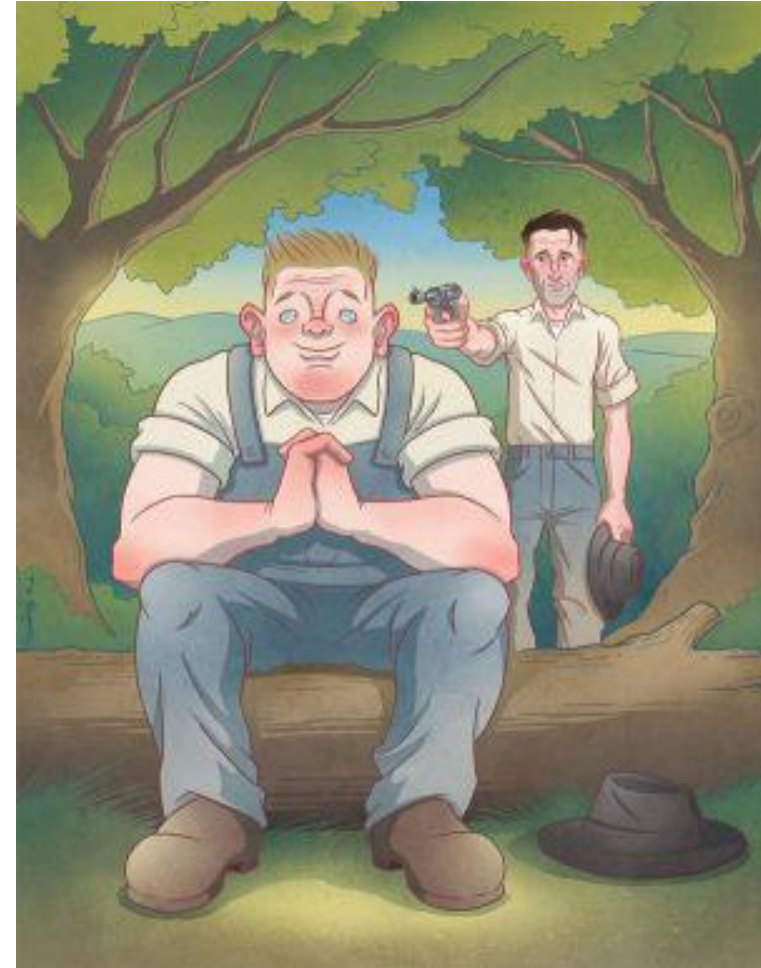
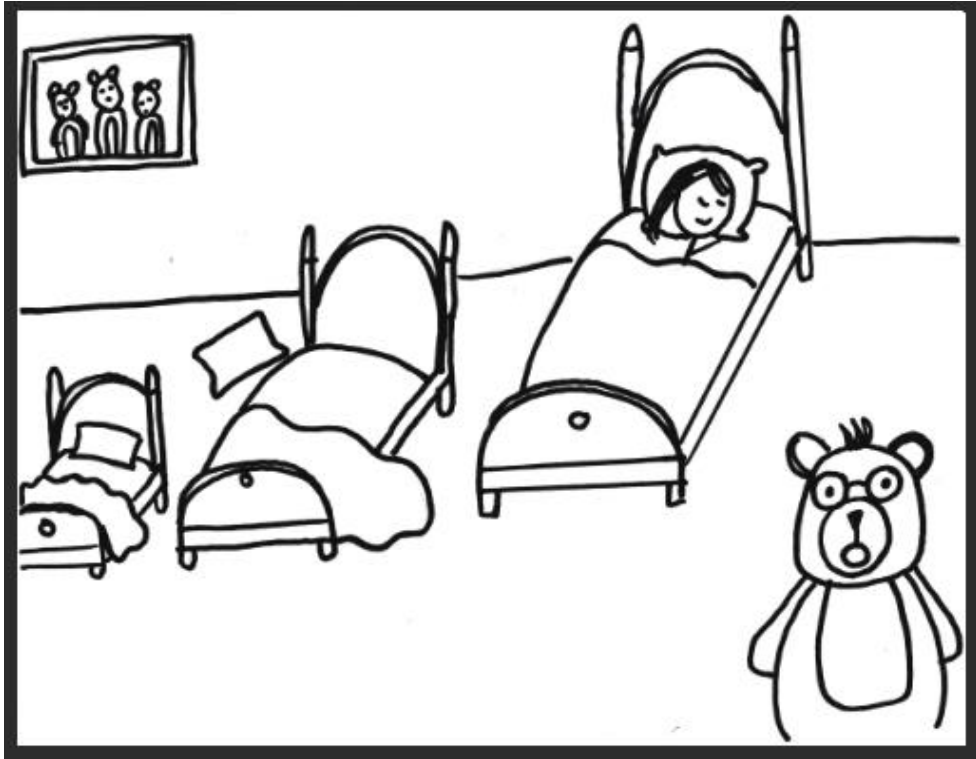

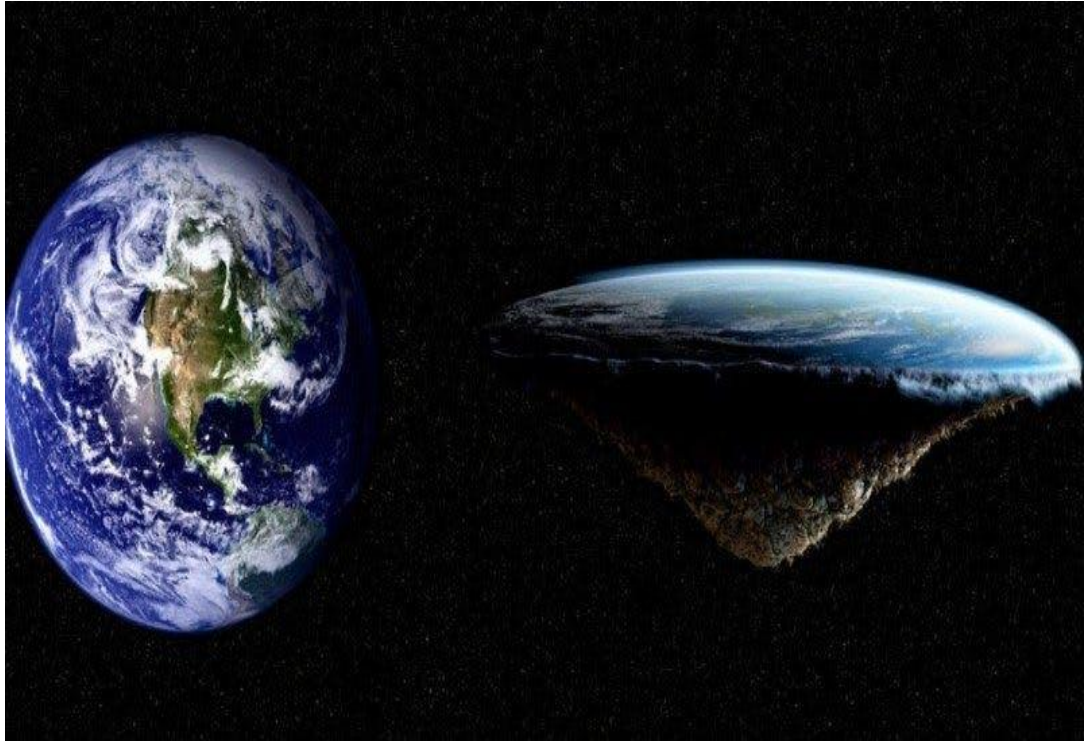

# MISTAKE ANALYSIS

- Which of these is the best answer (out of 2 wrong answers)? Why?
- What is the Joe Schmo answer?

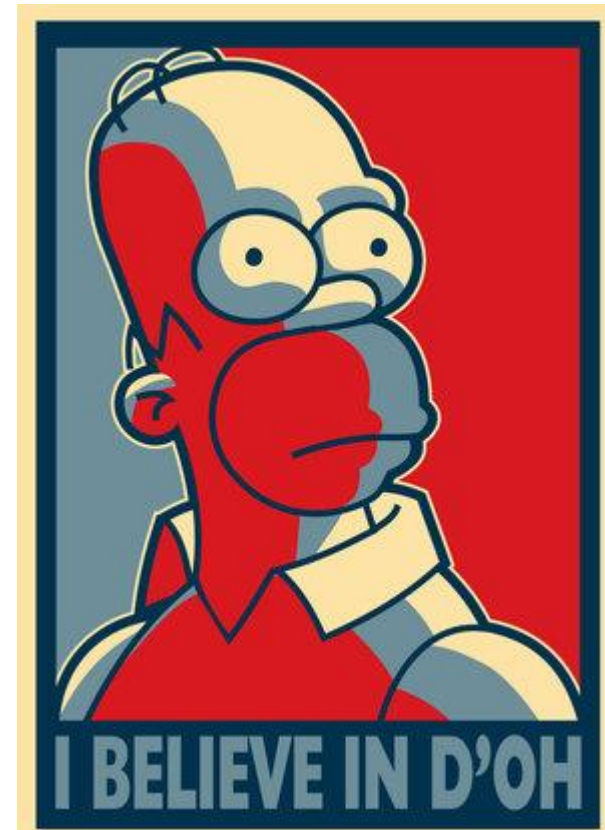

# OUR IMPACT

- Mack Middle School (Las Vegas, NV)
  - 75% of students referred to in-school suspension returned one or more times that same school year in the 2014-15 school year
  - 9% of students referred to in-school suspension returned one or more times that same school year in the 2015-16 school year
- Gila Bend Unified School District (Gila Bend, AZ)
  - “Out of control” bullying challenges during 2016-17 school year
  - Bullying programs, bullying awareness programs not making impact
  - Results pending, but school culture already shifting



Twitter: @thinkLawUS  
#Liberty2Learn #Golden Pencil



# What Teachers and Students Are Saying About thinkLaw

"" [thinkLaw] lessons are extremely interesting but also demand students to use their critical thinking skills. My class was 100% involved because they were the ones in charge here, while I took a back role and merely offered guidance instead of telling students what to think."

## thinkLaw's Impact

High Student Engagement



Rated thinkLaw favorably, or highly favorably

Improved willingness to apply critical thinking



Increased their understanding of different view points



Believed their ability to analyze arguments improved



*thinkLaw made me think in other ways rather than just **black and white**.*

*I now look at the minor details that I **never** used to look at.*

*thinkLaw taught me how to see things in a **different perspective**.*

*thinkLaw helped me become more **confident** in my abilities.*

# Additional Product Offerings

- ▶ Early Elementary Edition (K-2)



- ▶ Social Justice Edition



THINK  
LAW VOLUME 2

SOCIAL JUSTICE EDITION



- ▶ Parent Critical Thinking Seminar

- ▶ TPT Lessons for Current Events and Holiday-Themed Lessons

ELL and SPED Accommodations included for all lessons

## One Way to Beat an Opponent

*Analysis from Multiple Perspectives*



THINK  
LAW



# QUESTIONS/KEEPING IN TOUCH

- Like us on Facebook: thinkLaw
- Join our “Critical Thinking Champions” Facebook Group
- Follow us on Twitter @thinkLawUS
- **Text THINK to 66866 for a Free Sample Lesson**
- Email me at colin@thinkLaw to bring thinkLaw to your school/district
- Visit Booth #504 for more information/Grab handouts

***What critical thinking techniques  
you will bring back to your  
classrooms immediately?***



Twitter: @thinkLawUS  
#Liberty2Learn #Golden Pencil

